

Hyundai Warehouse Equipment

Electric Pallet truck, Electric Stacker and Manual Hand Pallet Truck

MOVING YOU FURTHER

HYUNDAI HEAVY INDUSTRIES



■ Photo may include optional equipment.

 **HYUNDAI**

Electric Pallet truck

15/18/20EP



■ Photo may include optional equipment.

Standard Configurations

15EP

- Lifting Capacity : 1500 kg
- Brushless Drive Motor 0.9 kW
- Lifting Motor : 0.8 kW
- Drive Wheel : 195 x 70mm
- Double Polyurethane Load wheels wheel (size: 80 x 70 mm)
- Hourmeter, Battery Discharge Indicator (BDI) & lift cut off
- Overall Fork Width x Length : 550 mm x 1150 mm
- Turtle switch / crawl speed button
- Belly switch
- Gel battery
- Integrated charger
- Emergency switch
- Ergonomic tiller

18EP

- Lifting Capacity : 1800 kg
- AC Drive Motor 1.2 kW
- Lift motor 1.2 kW
- Curtis controller
- Drive wheel : 250 x 70mm
- Double Polyurethane Load wheel wheel (size: 80 x 70 mm)
- Hourmeter, Battery Discharge Indicator (BDI) & lift cut off
- Overall Fork Width x Length : 550 mm x 1150 mm
- Turtle switch / crawl speed button
- Ergonomic low-mounted tiller
- Side Battery Removal
- Emergency switch
- Belly switch

20EP

- Lifting Capacity : 2000 kg
- AC Drive Motor 1.2 kW
- Lift motor 1.2 kW
- Curtis controller
- Drive wheel : 250 x 70mm
- Double Polyurethane Load wheel wheel (size: 82 x 98 mm)
- Hourmeter, Battery Discharge Indicator (BDI) & lift cut off
- Overall Fork Width x Length : 550 mm x 1150 mm
- Turtle switch / crawl speed button
- Ergonomic low-mounted tiller
- Side Battery Removal
- Emergency switch
- Belly switch

Advantages

SAFETY AND PRODUCTIVITY

- AC technology gives high performance and low maintenance (no carbon brushes)
- Intelligent regenerative brake system for fast and efficient handling
- Side battery removal, for multiple shift operation
- Turtle mode switch, for safe maneuverability with tiller in upright position
- Proportional speed control ensures precise operation
- Anti roll-back on gradients (parking brake)

STRUCTURE DESIGN

- The motor structure is resistant to dust and moisture
- Improved lateral stability thanks to spring applied castor wheels
- Torsion resistant forks, welded type

SERVICEABILITY

- Increased serviceability by CANbus technology
- Grease fittings on all pivot points increase durability
- Easy access to all components thanks to removal of only 1-piece front cover

Electric Pallet truck

Dimensions

15EP

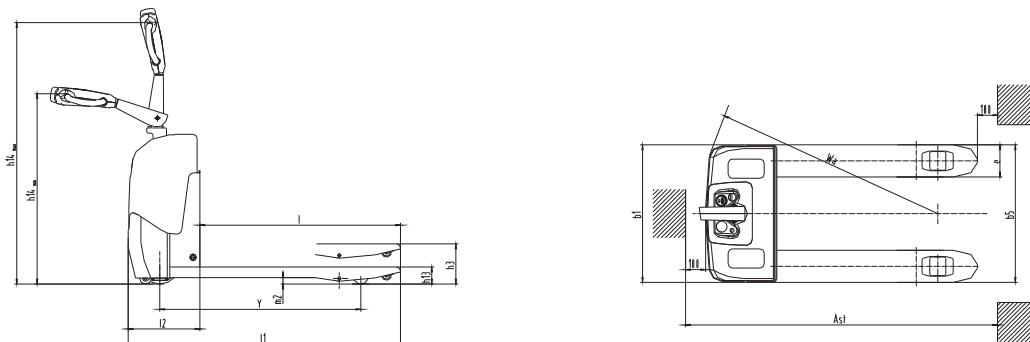

18/20EP

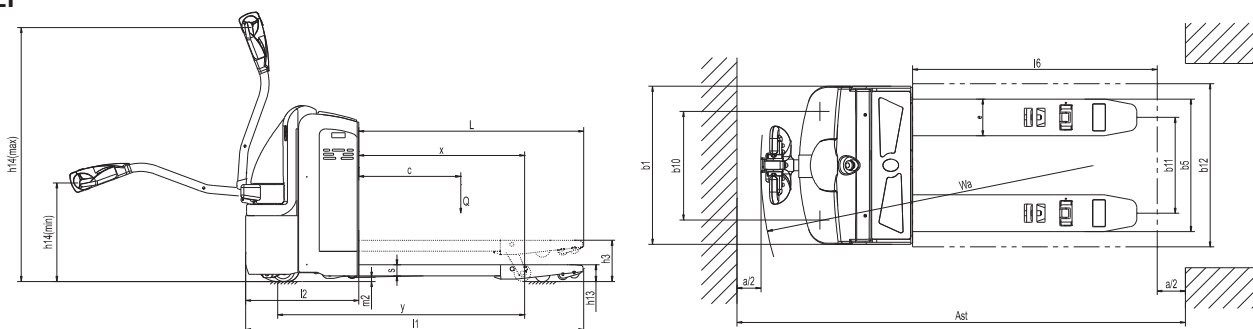

Option

15EP

- Loadguard 1220 mm
- Fork length (mm): 900; 1000; 1220
- Single PU Load Wheels (fork wheel size 80 x 70 mm)

18EP

- Integrated Charger (24V / 15A)
- Battery trolley
- Foot protection strip
- Keyless ignition (keypad)
- Loadguard 1220 mm
- Fork length (mm): 800; 900; 1000; 1220; 1600; 1800; 2400 mm
(1800; 2400 : rated load capacity 1.5t)

20EP

- Single PU load wheels (size 82 x 98)
- Integrated Charger (24V / 15A)
- Battery trolley
- Foot protection strip
- Keyless ignition (keypad)
- Loadguard 1220 mm
- Fork length (mm): 800; 900; 1000; 1220; 1600; 1800; 2400 mm
(1800; 2400 : rated load capacity 1.5t)

Specification (according to VDI 2198)

Characteristics						
1.1	manufacturer (abbreviation)			Hyundai	Hyundai	Hyundai
1.2	Model			15EP	18EP	20EP
1.3	Drive type			electric	electric	electric
1.4	Operator type			pedestrian	pedestrian	pedestrian
1.5	Load capacity/rated load	Q	kg	1500	1800	2000
1.6	Load center distance	c	mm	600	600	600
1.8	Load distance	x	mm	886 / 956	856	815 / 865 / 935
1.9	Wheelbase	y	mm	1152 / 1222	1200	1211 / 1261 / 1331
Weight						
2.1	Service weight(with battery)		kg	230	520	620
2.2	Axle load, front/rear, loaded		kg	442 / 1288	720 / 1600	1170 / 1450
2.3	Axle load, front/rear, unloaded		kg	200 / 30	420 / 100	470 / 150
Wheels/Chassis						
3.1	Tyres: solid rubber, superelastic, pneumatic, polyurethane			polyurethane	polyurethane	polyurethane
3.2	Tyre size, front			Φ 195 x 70	Φ 250 x 70	Φ 250 x 70
3.3	Tyre size, rear			Φ 80 / Φ 70	Φ 80 x 70	Φ 82 x 126
3.4	Additional wheels(dimensions)			Φ 60 x 35	Φ 114 x 60	Φ 127 x 57
3.5	Wheels number, front/rear (x = driven wheels)			1x -2/4	1x +2/4	1x +2/2
3.6	Tread, front	b10	mm	195	476	510
3.7	Tread, rear	b11	mm	80 / 74	400	340 / 370 / 470 / 505
Dimension						
4.4	Lift height	h5	mm	105 / 115	120	120
4.9	Min. /Max. height of operation handle, in driving position	h14	mm	950 / 1310	780 / 1230	780 / 1230
4.15	Height, lowered	h13	mm	85 / 75	84	82
4.19	Overall length	l1	mm	1525 / 1595	1651	1655 / 1705 / 1775
4.20	Length to fork face	l2	mm	373	500	555
4.21	Overall width of truck body	b1	mm	685	682	775
4.22	Fork dimension	s/e/l	mm	53 x 160 x 1150	54 x 150 x 1150	54 x 180 x 1150
4.25	Overall width of fork	b5	mm	520 / 550 / 685	550	520 / 550 / 650 / 685
4.32	Wheelbase ground distance	m2	mm	32 / 22	28	28
4.33	Aisle width, with pallet 1000 x 1200 crosswise	Ast	mm	1725 / 1795	1863	2015 / 2065 / 2135
4.34	Aisle width, with pallet 800 x 1200 lengthwise	Ast	mm	1775 / 1795	1913	2115 / 2115 / 2135
4.35	Turning radius	Wa	mm	1347 / 1415	1367	1400 / 1450 / 1520
Performance Data						
5.1	traveling speed, loaded/unloaded		km/h	5.3 / 5.8	6 / 6	5.5 / 5.6
5.2	Lifting speed, loaded/unloaded		m/s	0.035 / 0.045	0.06 / 0.11	0.039 / 0.056
5.3	Lowering speed, loaded/unloaded		m/s	0.08 / 0.037	0.12 / 0.13	0.064 / 0.050
5.7	Gradeability, loaded/unloaded		%	5 / 15	8 / 20	6 / 12
5.10	traveling brake			electromagnetic brake	electromagnetic brake	electromagnetic brake
Motor						
6.1	Driving motor power		kW	0.9	1.2	1.2
6.2	Lifting motor power		kW	0.8	1.2	1.2
6.4	Battery voltage/rated capacity		V/Ah	24 / 80	24 / 160	24 / 210
6.5	Battery weight		kg	49	160	170

Electric Pallet truck

20/25EPR



■ Photo may include optional equipment.

Standard Configurations

20EPR

- Lifting Capacity : 2000 kg
- AC Drive Motor 1.5 kW (9 km/h)
- Lift motor 1.2 kW
- Curtis controller
- Drive wheel : 250 x 70 mm
- Double Polyurethane load wheels; wheel size 82 x 98mm
- Hourmeter, battery discharge indicator (BDI) & lift cut off
- Overall Fork Width x Length : 550 mm x 1150 mm
- Turtle switch / crawl speed button
- Tiller head with big control buttons
- Side Battery Removal
- EPS (Electric Power Steering)
- Stand on platform

25EPR

- Lifting Capacity : 2500 kg
- AC Drive Motor 1.5 kW (6 Km/h)
- Lift motor 1.2 kW
- Curtis controller
- Drive wheel : 250 x 70 mm
- Double Polyurethane Load wheel wheel size 82 x 98 mm
- Hourmeter, battery discharge indicator (BDI) & lift cut off
- Overall Fork Width x Length : 550 mm x 1150 mm
- Turtle switch / crawl speed button
- Tiller head with big control buttons
- Side Battery Removal
- EPS (Electric Power Steering)
- Stand on platform

Advantages

SAFETY AND PRODUCTIVITY

- AC technology gives high performance and low maintenance (no carbon brushes)
- Intelligent regenerative brake system: increase overall truck performance.
- Side battery removal, for multiple shift operation
- Turtle mode switch, for safe maneuverability with tiller in upright position
- Proportional travel speed control
- Anti roll-back on gradients
- Effortless steering (EPS), less fatigue
- Automatic speed reduction relative to steer angle
- Suspended platform for comfortable operation

STRUCTURE DESIGN

- The closed motor structure is water- and dust resistant (IP 44)
- Spring-loaded castors improve lateral stability on uneven floors and enhance truck performance and service life.
- Welded type fork.

SERVICEABILITY

- CANbus technology reduces wiring complexity.
- All pivot points have grease fittings and serviceable bushings, to reduce component-wearing.
- Easy access to all components thanks to removal of 1-piece front cover.

Electric Pallet truck

Dimensions

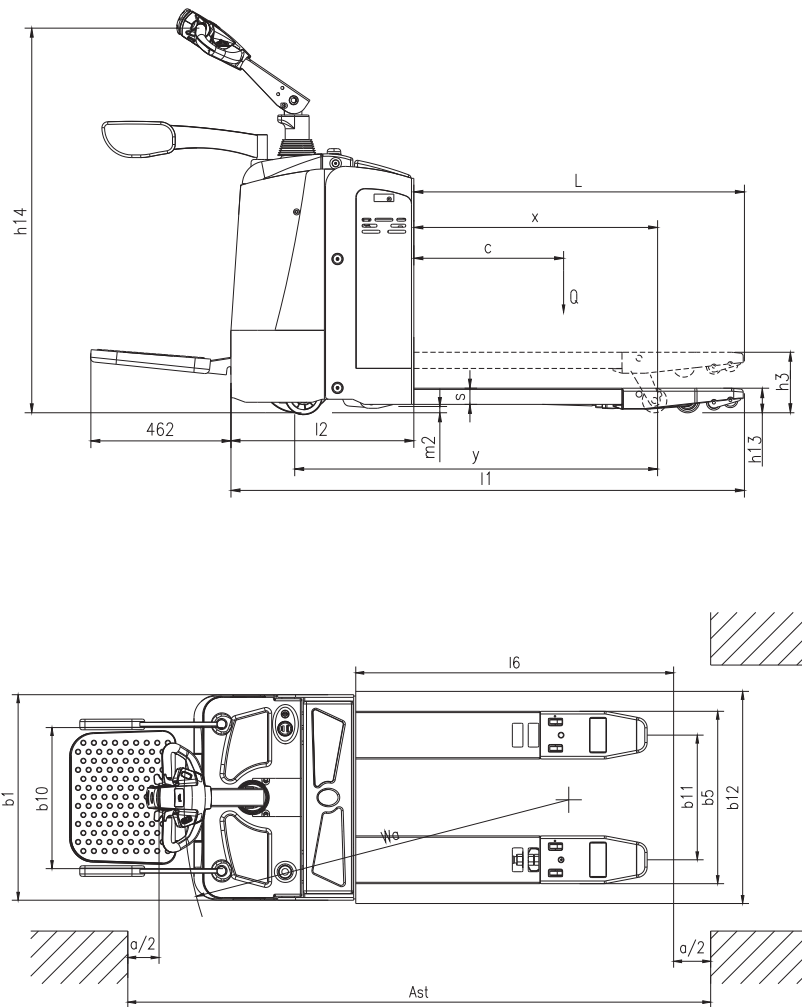

Option

- Traveling speed 6 km/h
- (1.6 kw Drive motor, Curtis controller 1232)
- Curtis steering controller
- Integrated charger (24V / 20A)
- Coldstore specification -18°C
- Closed operator protection
- Keyless ignition (keypad) (start)
- Loadguard 1220 mm
- Battery trolley
- Fork length (mm)
 - 20EPR : 800; 900; 1000; 1200; 1600; 1800; 2400
 - 25EPR : 800; 900; 1000; 1200; 1600; 1800; 2400
 - (1800; 2400 : rated load capacity 1.5t)

Specification (according to VDI 2198)

Characteristics					
1.1	manufacturer (abbreviation)			Hyundai	Hyundai
1.2	Model			20EPR	25EPR
1.3	Drive type			Electric	Electric
1.4	Operator type			pedestrian / standing	pedestrian / standing
1.5	Load capacity/rated load	Q	kg	2000	2500
1.6	Load center distance	c	mm	600	600
1.8	Load distance	x	mm	818 / 868 / 938	818 / 868 / 938
1.9	Wheelbase	y	mm	1302 / 1352 / 1422	1302 / 1352 / 1422
Weight					
2.1	Service weight(with battery)		kg	720	720
2.2	Axle load, front/rear, loaded		kg	1640 / 1030	2040 / 1180
2.3	Axle load, front/rear, unloaded		kg	160 / 560	160 / 560
Wheels/Chassis					
3.1	Tyres: solid rubber, superelastic, pneumatic, polyurethane			polyurethane	polyurethane
3.2	Tyre size, front			Φ 250 × 70	Φ 250 × 70
3.3	Tyre size, rear			Φ 80 × 70	Φ 74 × 70
3.4	Additional wheels(dimensions)			Φ 127 × 57	Φ 127 × 57
3.5	Wheels number, front/rear (x = driven wheels)			1x +2/4	1x +2/4
3.6	Tread, front	b10	mm	491	491
3.7	Tread, rear	b11	mm	340 / 370 / 470 / 505	340 / 370 / 470 / 505
Dimension					
4.4	Lift height	h5	mm	120	120
4.9	Min. /Max. height of operation handle, in driving position	h14	mm	1150 / 1450	1150 / 1450
4.15	Height, lowered	h13	mm	75 / 85	75 / 85
4.19	Overall length	l1	mm	1823 / 1873 / 1943	1823 / 1873 / 1943
4.20	Length to fork face	l2	mm	723	723
4.21	Overall width of truck body	b1	mm	733	733
4.22	Fork dimension	s/e/l	mm	53 × 180 × 1100 (1150 / 1220)	53 × 180 × 1100 (1150 / 1220)
4.25	Overall width of fork	b5	mm	520 / 550 / 650 / 685	520 / 550 / 650 / 685
4.32	Wheelbase ground distance	m2	mm	30	30
4.33	Aisle width, with pallet 1000 x 1200 crosswise	Ast	mm	2135 / 2185 / 2255	2135 / 2185 / 2255
4.34	Aisle width, with pallet 800 x 1200 lengthwise	Ast	mm	2235 / 2235 / 2255	2235 / 2235 / 2255
4.35	Turning radius	Wa	mm	1700 / 1750 / 1820	1700 / 1750 / 1820
Performance Data					
5.1	traveling speed, loaded/unloaded		km/h	7.9 / 8	6.7 / 6.8
5.2	Lifting speed, loaded/unloaded		m/s	0.03 / 0.032	0.03 / 0.032
5.3	Lowering speed, loaded/unloaded		m/s	0.032 / 0.03	0.032 / 0.03
5.7	Gradeability, loaded/unloaded		%	4 / 8	3 / 8
5.8	Max. gradeability, loaded/unloaded			8 / 20	6 / 20
5.10	traveling brake			electromagnetic brake	electromagnetic brake
Motor					
6.1	Driving motor power		kW	1.5	1.5
6.2	Lifting motor power		kW	1.5	1.5
6.4	Battery voltage/rated capacity		V/Ah	24 / 240	24 / 240
6.5	Battery weight		kg	240	240

Electric pallet truck (Double deck)

20EDPR



■ Photo may include optional equipment.

Standard Configurations

20EDPR

- Lifting Capacity: 1x 2000 kg (2x 1000 kg)
- AC Drive Motor 1.5 kW
- Lift motor 2.2 kW
- Curtis controller
- Drive wheel: 250 x 70mm
- Double Polyurethane Load wheel size 80 x 70 mm
- Lift height 2500 mm (Triple mast free lift)
- Hourmeter, battery discharge indicator (BDI) with lift cut off
- Overall Fork Width x Length: 570 x 1150 mm
- Tiller head with big proportional controls
- Side Battery Removal
- EPS (Electric Power Steering)
- Maximum travelling speed: 9 Km/h
- Stand on platform
- Loadguard

Advantages

SAFETY AND PRODUCTIVITY

- AC technology gives high performance and low maintenance (no carbon brushes)
- Intelligent regenerative brake system: increase overall truck performance.
- Side battery removal, for multiple shift operation
- Turtle mode switch, for safe maneuverability with tiller in upright position
- Proportional travel speed control
- Anti roll-back on gradients
- Effortless steering (EPS), less fatigue
- Automatic speed reduction relative to steer angle
- Suspended platform for comfortable operation
- Precision in handling due to proportional hydraulics

STRUCTURE DESIGN

- The closed motor structure is water- and dust resistant (IP 44)
 - Spring-loaded castors improve lateral stability on uneven floors and enhance truck performance and service life.
- Welded type fork.

SERVICEABILITY

- CANbus technology reduces wiring complexity.
- All pivot points have grease fittings and serviceable bushings, to reduce component-wearing.
- Easy access to all components thanks to removal of 1-piece front cover.

Electric Pallet Truck Double Deck

Dimensions

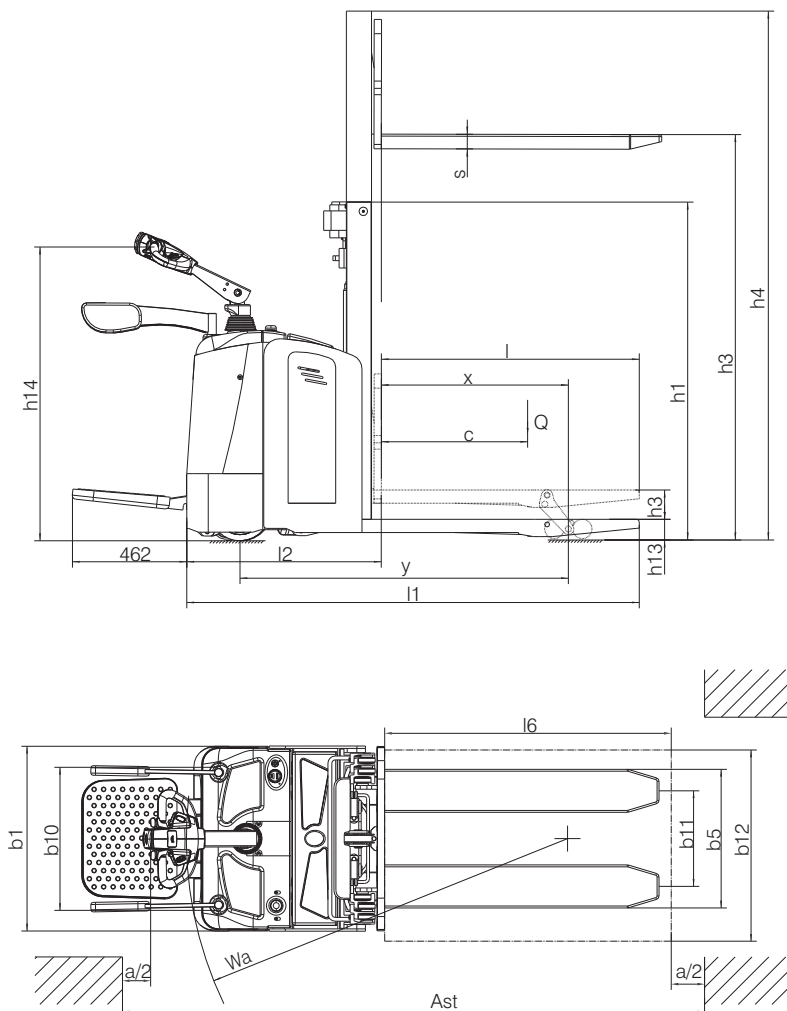

Option

- Coldstore specification -18°C
- Keyless ignition (keypad)
- Battery trolley
- Fork length (mm): 800; 900; 1000; 1220
- Lifting height 1600 mm (Triple mast free lift)
- Lifting height 2000 mm (Triple mast free lift)
- Single PU load wheel

Specification (according to VDI 2198)

Characteristics				
1.1	manufacturer (abbreviation)			Hyundai
1.2	Model			20EDPR
1.3	Drive type			electric
1.4	Operator type			pedestrian / standing
1.5	Load capacity/rated load	Q	kg	2000
1.6	Load center distance	c	mm	600
1.8	Load distance	x	mm	767
1.9	Wheelbase	y	mm	1348
Weight				
2.1	Service weight(with battery)		kg	1130
2.2	Axle load, front/rear, loaded		kg	1090 / 2040
2.3	Axle load, front/rear, unloaded		kg	840 / 290
Wheels/Chassis				
3.1	Tyres: solid rubber, superelastic, pneumatic, polyurethane			polyurethane
3.2	Tyre size, front			Φ 250 × 70
3.3	Tyre size, rear			Φ 80 × 70
3.4	Additional wheels(dimensions)			Φ 127 × 57
3.5	Wheels number, front/rear (x = driven wheels)			1x +2/4
3.6	Tread, front	b10	mm	490
3.7	Tread, rear	b11	mm	400 / 470
Dimension				
4.2	Height of mast, lowered	h1	mm	1082 / 1212 / 1382
4.4	Lift height	h5	mm	1600 / 2000 / 2500
4.5	Max. height of mast, extended	h3	mm	2118 / 2508 / 3018
4.7	Lifting height for leg	h4	mm	120
4.9	Min. /Max. height of operation handle, in driving position	h14	mm	1150 / 1430
4.15	Height, lowered	h13	mm	90
4.19	Overall length	l1	mm	1898 / 1948
4.20	Length to fork face	l2	mm	798
4.21	Overall width of truck body	b1	mm	775
4.22	Fork dimension	s/e/l	mm	54 × 180 × 1150
4.25	Overall width of fork	b5	mm	580 / 650
4.32	Wheelbase ground distance	m2	mm	28
4.33	Aisle width, with pallet 1000 x 1200 crosswise	Ast	mm	2098 / 2148
4.34	Aisle width, with pallet 800 x 1200 lengthwise	Ast	mm	2198
4.35	Turning radius	Wa	mm	1600
Performance Data				
5.1	traveling speed, loaded/unloaded		km/h	9 / 9.1
5.2	Lifting speed, loaded/unloaded		m/s	0.03 / 0.04
5.3	Lowering speed, loaded/unloaded		m/s	0.05 / 0.045
5.7	Gradeability, loaded/unloaded		%	6 / 12
5.8	Max. gradeability, loaded/unloaded			8 / 20
5.10	traveling brake			electromagnetic braking
Motor				
6.1	Driving motor power		kW	1.5
6.2	Lifting motor power		kW	2.2
6.4	Battery voltage/rated capacity		V/Ah	24 / 240
6.5	Battery weight		kg	235

Electric Pallet truck

10/12/15ES



■ Photo may include optional equipment.

Standard Configurations

10ES

- Lifting Capacity : 1000 kg
- AC Drive Motor 1.2 kW / Lift motor 2.2 kW
- Curtis controller
- Drive wheel : 250 x 70 mm
- Double Polyurethane Load wheels wheel (size: 80 x 70 mm)
- Hourmeter, battery discharge indicator (BDI) & lift cut off
- Duplex 3.0 m Mast without free lift
- Overall Fork Width x Length : 580 mm x 1150 mm
- Turtle switch / crawl speed button
- Tiller head with big control buttons
- Automatic Drive speed reduction (lifting over 1.8 m)
- Ergonomic low-mounted tiller
- Loadguard

12ES

- Lifting Capacity : 1200 kg
- AC Drive Motor 1.2 kW / Lift motor 2.2 kW
- Curtis controller
- Drive wheel : 250 x 70 mm
- Double Polyurethane Load wheel wheel (size: 80 x 70 mm)
- Hourmeter, battery discharge indicator (BDI) & lift cut off
- Duplex 3.0 m Mast without free lift
- Overall Fork Width x Length : 580 mm x 1150 mm
- Turtle switch / crawl speed button
- Tiller head with big control buttons
- Automatic Drive speed reduction (lifting over 1.8 m)
- Ergonomic low-mounted tiller
- Loadguard

15ES

- Lifting Capacity : 1500 kg
- AC Drive Motor 1.5 kW / Lift motor 3.2 kW
- Curtis controller
- Drive wheel : 250 x 70 mm
- Double Polyurethane Load wheels wheel (size: 84 x 80 mm)
- Hourmeter, battery discharge indicator (BDI) & lift cut off
- Duplex 3.0 m Mast with free lift
- Overall Fork Width x Length : 570 mm x 1150 mm
- Turtle switch / crawl speed button
- Tiller head with big control buttons
- Proportional Lifting
- Automatic Drive speed reduction (lifting over 1.8m)
- Ergonomic low-mounted tiller
- Loadguard

Advantages

SAFETY AND PRODUCTIVITY

- AC technology gives high performance and low maintenance (no carbon brushes)
- Multi-functional display with BDI and hour meter.
- Proportional travel speed control.
- Switch shuts off liftmotor.
- Intelligent regenerative brake system for fast and efficient handling
- Proportional speed control ensures precise operation
- Anti roll-back on gradients (parking brake)
- Precision in storage and retrieval operations due to proportional hydraulics (15ES)
- Side battery removal for multiple shift operations
- Turtle mode switch, for safe maneuverability with tiller in upright position
- Long tiller ensures large safety distance between operator and truck

STRUCTURE DESIGN

- The closed motor structure is water- and dust resistant
- Improved lateral stability thanks to spring applied castor wheels
- Torsion resistant forks, welded type
- Offset low mounted tiller for improved visibility
- Lifting heights up to 5000 mm

SERVICEABILITY

- CANbus technology reduces wiring complexity.
- All pivot points have grease fittings and serviceable bushings, to reduce component-wearing.
- Easy access to all components thanks to removal of 1-piece front cover.

Electric Pallet truck

Dimensions

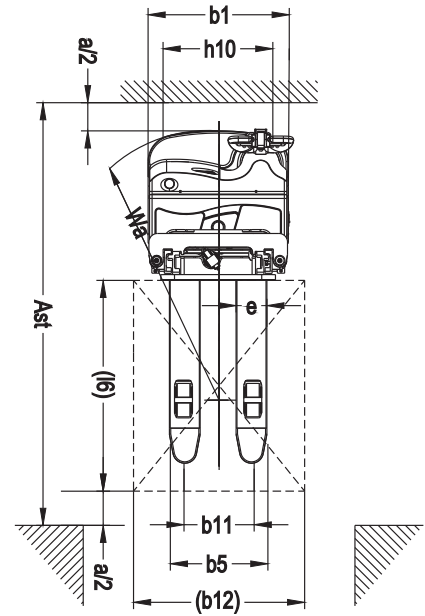
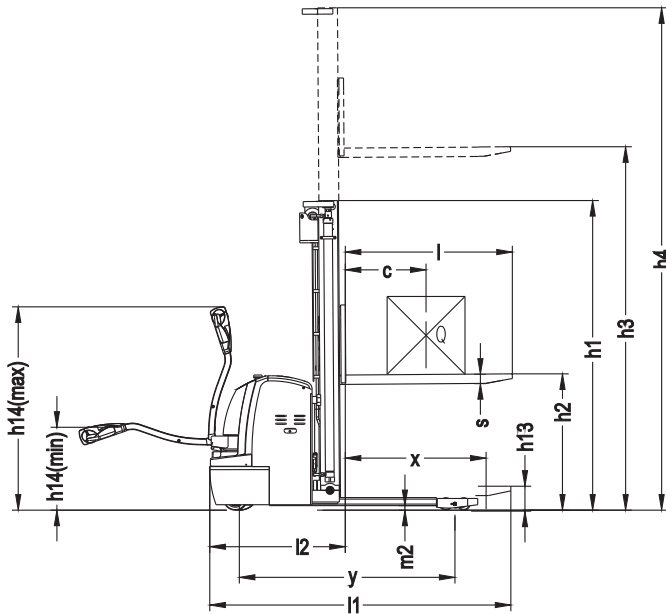

Lifting capacity

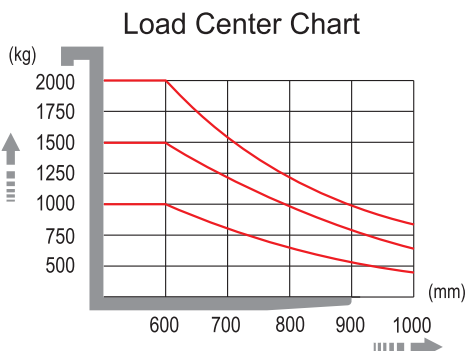
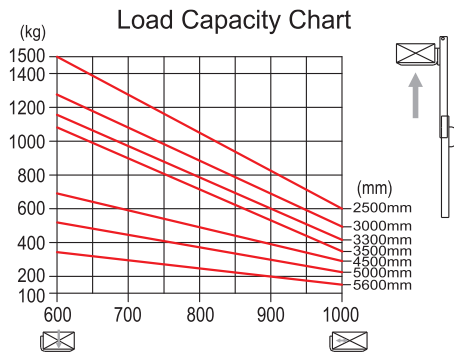

Option

- Integrated Charger
 - 10/12 ES : (24V/15A)
 - 15 ES : (24V/30A)
- Keyless ignition (keypad)
- Battery trolley
- Fork length (mm)
 - 10/12/15 ES : 800; 900; 1000; 1200

10/12ES

- Lifting height 2500 mm, Duplex mast without free lift
- Lifting height 3300 mm, Duplex mast without free lift

15ES

- Tiller head with big control buttons
- Coldstore specification -18°C
- Initial lift
- Lifting height 3000 mm, Duplex mast without free lift
- Lifting height 3500 mm, Duplex mast without free lift
- Lifting height 2500 mm, Duplex mast with free lift
- Lifting height 3500 mm, Duplex mast with free lift
- Lifting height 4500 mm, Triplex mast with free lift
- Lifting height 5000 mm, Triplex mast with free lift
- Lifting height 5600 mm, Triplex mast with free lift

Specification (according to VDI 2198)

Characteristics						
1.1	manufacturer (abbreviation)			Hyundai	Hyundai	Hyundai
1.2	Model			10ES	12ES	15ES
1.3	Drive type			electric	electric	electric
1.4	Operator type			pedestrian	pedestrian	pedestrian
1.5	Load capacity/rated load	Q	kg	1000	1200	1500
1.6	Load center distance	c	mm	500	500	600
1.8	Load distance	x	mm	697	697	697
1.9	Wheelbase	y	mm	1335	1335	1383
Weight						
2.1	Service weight(with battery)		kg	700 / 730 / 750	710 / 740 / 760	1230 / 1245 / 1260 / 1270
2.2	Axle load, front/rear, loaded		kg	950 / 770	1060 / 870	1470 / 1310
2.3	Axle load, front/rear, unloaded		kg	555 / 165	560 / 170	900 / 380
Wheels/Chassis						
3.1	Tyres: solid rubber, superelastic, pneumatic, polyurethane			polyurethane	polyurethane	polyurethane
3.2	Tyre size, front			φ 250 × 70	φ 250 × 70	φ 250 × 70
3.3	Tyre size, rear			φ 80 × 70	φ 80 × 70	φ 80 × 84
3.4	Additional wheels(dimensions)			φ 150 × 60	φ 150 × 60	φ 150 × 60
3.5	Wheels number, front/rear (x = driven wheels)			1x+1/4	1x+1/4	1x+1/4
3.6	Tread, front	b10	mm	520	520	520
3.7	Tread, rear	b11	mm	410 / 525	410 / 525	404 / 525
Dimension						
4.2	Height of mast, lowered	h1	mm	2087 / 1837 / 2087 / 2237	2087 / 1837 / 2087 / 2237	1735 / 1985 / 2135 / 2235
4.3	Free lift height (optional)			N/A	N/A	1300 / 1550 / 1700 / 1800
4.4	Lift height	h3	mm	1600 / 2500 / 3000 / 3300	1600 / 2500 / 3000 / 3300	2500 / 3000 / 3300 / 3500
4.5	Max. height of mast, extended	h4	mm	2087 / 3087 / 3587 / 3887	2087 / 3087 / 3587 / 3887	2955 / 3455 / 3755 / 3955
4.9	Min. /Max. height of operation handle, in driving position	h14	mm	670 / 1300	670 / 1300	670 / 1300
4.15	Height, lowered	h13	mm	90	90	90
4.19	Overall length	l1	mm	1965	1965	1950
4.20	Length to fork face	l2	mm	792	792	878
4.21	Overall width of truck body	b1	mm	820	820	820
4.22	Fork dimension	s/e/l	mm	60 / 170 / 1070 (1150)	60 / 170 / 1070 (1150)	60 / 180 / 1070 (1150)
4.25	Overall width of fork	b5	mm	580 / 695	580 / 695	570 / 695
4.32	Wheelbase ground distance	m2	mm	28	28	31
4.33	Aisle width, with pallet 1000 x 1200 crosswise	Ast	mm	2400	2400	2450
4.34	Aisle width, with pallet 800 x 1200 lengthwise	Ast	mm	2370	2370	2420
4.35	Turning radius	Wa	mm	1525	1525	1575
Performance Data						
5.1	traveling speed, loaded/unloaded		km/h	5.3 / 5.6	5.3 / 5.6	5.8 / 6
5.2	Lifting speed, loaded/unloaded		m/s	0.06 / 0.13	0.06 / 0.13	0-0.12 / 0-0.19
5.3	Lowering speed, loaded/unloaded		m/s	0.13 / 0.10	0.13 / 0.10	0-0.35 / 0-0.12
5.7	Gradeability, loaded/unloaded		%	6 / 15	6 / 15	8 / 15
5.10	traveling brake			electromagnetic brake	electromagnetic brake	electromagnetic brake
Motor						
6.1	Driving motor power		kW	1.2 (AC)	1.2 (AC)	1.5 (AC)
6.2	Lifting motor power		kW	2.2	2.2	3.2
6.4	Battery voltage/rated capacity		V/Ah	24 / 120	24 / 120	24 / 300
6.5	Battery weight		kg	90	90	300

Electric Stacker

12ESN



■ Photo may include optional equipment.

Standard Configurations

12ESN

- Lifting Capacity : 1200 kg
- AC Drive Motor 1.2 kW
- Lift motor : 2.2 kW
- Curtis controller
- Drive wheel : 250 x 70 mm
- Double Polyurethane Load wheel wheel size 80 x 70 mm
- Hourmeter, battery discharge indicator (BDI) & lift cut off
- Simplex mast, Lifting height 1950 mm
- Lowered Height : 2.33 m
- Ergonomic low-mounted tiller
- Overall Fork Width x Length : 570 mm x 1150 mm
- Turtle switch / crawl speed button
- Automatic drive speed reduction (lifting over 1.8 m)
- Integrated charger
- Belly Switch
- Gel battery

Advantages

SAFETY AND PRODUCTIVITY

- AC technology gives high performance and low maintenance (no carbon brushes)
- Intelligent regenerative brake system.
- Multi-function display with BDI and hour meter etc.
- Proportional travel speed control.
- Switch shuts off liftmotor
- Turtle mode switch, for safe maneuverability with tiller in upright position
- Long tiller ensures large safety distance between operator and truck

STRUCTURE DESIGN

- The closed motor structure is water- and dust resistant
- Offset low mounted tiller for improved visibility

SERVICEABILITY

- Easy access to all components thanks to removal of 1-piece front cover
- Maintenance free gel battery

Electric Stacker

Dimensions

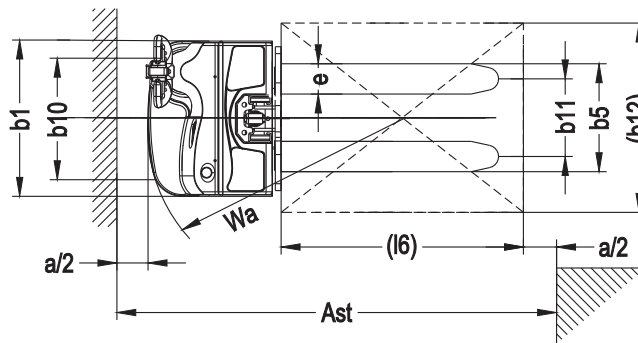
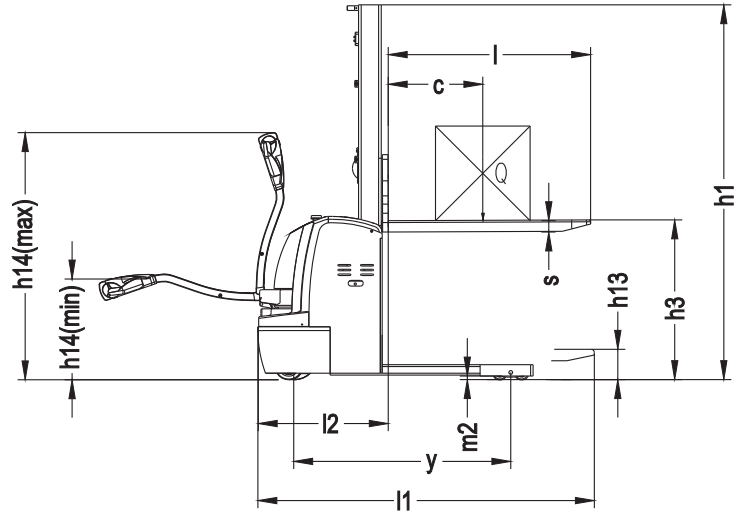

Lifting capacity

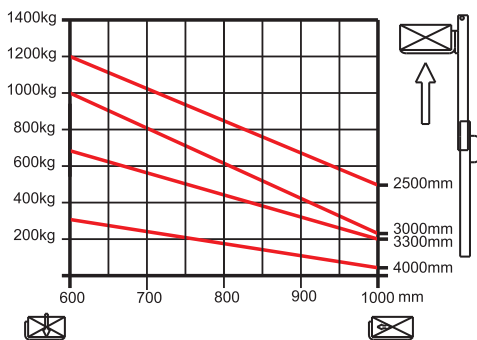

Option

- Lifting height 1600 mm
- Lifting height 2800 mm
- Fork length (mm): 800; 900; 1000; 1200

Specification (according to VDI 2198)

Characteristics				
1.1	manufacturer (abbreviation)			Hyundai
1.2	Model			12ESN
1.3	Drive type			electric
1.4	Operator type			walking
1.5	Load capacity/rated load	Q	kg	1200
1.6	Load center distance	c	mm	500
1.8	Load distance	x	mm	630
1.9	Wheelbase	y	mm	1146
Weight				
2.1	Service weight(with battery)		kg	590
2.2	Axle load, front/rear, loaded		kg	790 / 1000
2.3	Axle load, front/rear, unloaded		kg	195 / 395
Wheels/Chassis				
3.1	Tyres: solid rubber, superelastic, pneumatic, polyurethane			polyurethane
3.2	Tyre size, front			φ 250 × 70
3.3	Tyre size, rear			φ 80 × 70
3.4	Additional wheels(dimensions)			φ 150 × 60
3.5	Wheels number, front/rear (x = driven wheels)			1x +1/4
3.6	Tread, front	b10	mm	520
3.7	Tread, rear	b11	mm	400
Dimension				
4.2	Height of mast, lowered	h1	mm	1980 / 2330
4.4	Lift height	h5	mm	1600 / 1950
4.5	Max. height of mast, extended	h4	mm	1980 / 2330
4.9	Min. /Max. height of operation handle, in driving position	h14	mm	670 / 1300
4.15	Height, lowered	h13	mm	90
4.19	Overall length	l1	mm	1780 / 1860
4.20	Length to fork face	l2	mm	708
4.21	Overall width of truck body	b1	mm	820
4.22	Fork dimension	s/e/l	mm	1070 / 1150
4.25	Overall width of fork	b5	mm	570
4.32	Wheelbase ground distance	m2	mm	30
4.33	Aisle width, with pallet 1000 x 1200 crosswise	Ast	mm	2180
4.34	Aisle width, with pallet 800 x 1200 lengthwise	Ast	mm	2220
4.35	Turning radius	Wa	mm	1338
Performance Data				
5.1	traveling speed, loaded/unloaded		km/h	5.3 / 5.6
5.2	Lifting speed, loaded/unloaded		m/s	0.11 / 0.19
5.3	Lowering speed, loaded/unloaded		m/s	0.16 / 0.11
5.8	Max. gradeability, loaded/unloaded			6 / 15
5.10	traveling brake			electromagnetic brake
Motor				
6.1	Driving motor power		kW	1.2 (AC)
6.2	Lifting motor power		kW	2.2
6.4	Battery voltage/rated capacity		V/Ah	24/80
6.5	Battery weight		kg	50

Electric Stacker

15ESR



■ Photo may include optional equipment.

Standard Configurations

15ESR

- Lifting Capacity : 1500 kg
- AC Drive Motor 1.5 kW
- 8.5 km/h
- Lift motor 3.2 kW
- Curtis controller
- Drive wheel : 250 x 70 mm
- Double Polyurethane Load wheels wheel size 84 x 80mm
- Hourmeter, battery discharge indicator (BDI) & Limiter with lift cut off
- Duplex 3.0m Mast with free lift
- Fork Width x Length : 570 mm x 1150 mm
- Turtle switch / crawl speed button
- German Frei tiller with convenient control buttons
- Proportional Lifting
- Automatic speed reduction(lifting over 1.8 m)
- Belly switch
- Side battery removal
- Stand on platform
- EPS
- travel speed reduction

Advantages

SAFETY AND PRODUCTIVITY

- AC technology gives high performance and low maintenance (no carbon brushes)
- Mast lowering damping cushion
- Multi-functional display with BDI and hour meter etc.
- Side battery removal for multiple shift operation
- Auto deceleration function.
- Turtle mode switch, for safe maneuverability with tiller in upright position .
- Proportional travel speed control.
- Effortless steering (EPS), less fatigue
- Suspended platform for comfortable operation
- Intelligent regenerative brake system for fast and efficient handling
- Precision in handling due to proportional hydraulics
- Anti roll-back on gradients (parking brake)
- Lift limit switch shuts off liftmotor at max lifting height

STRUCTURE DESIGN

- The closed motor structure is water- and dust resistant (IP 44)
- Spring-loaded castors improve lateral stability on uneven floors and enhance truck performance and service life.
- Welded type fork.
- Lifting height up to 5600 mm

SERVICEABILITY

- CANbus technology reduces wiring complexity.
- All pivot points have grease fittings and serviceable bushings, to reduce component-wearing.
- Easy access to all components thanks to removal of 1-piece front cover.

Electric Stacker

Dimensions

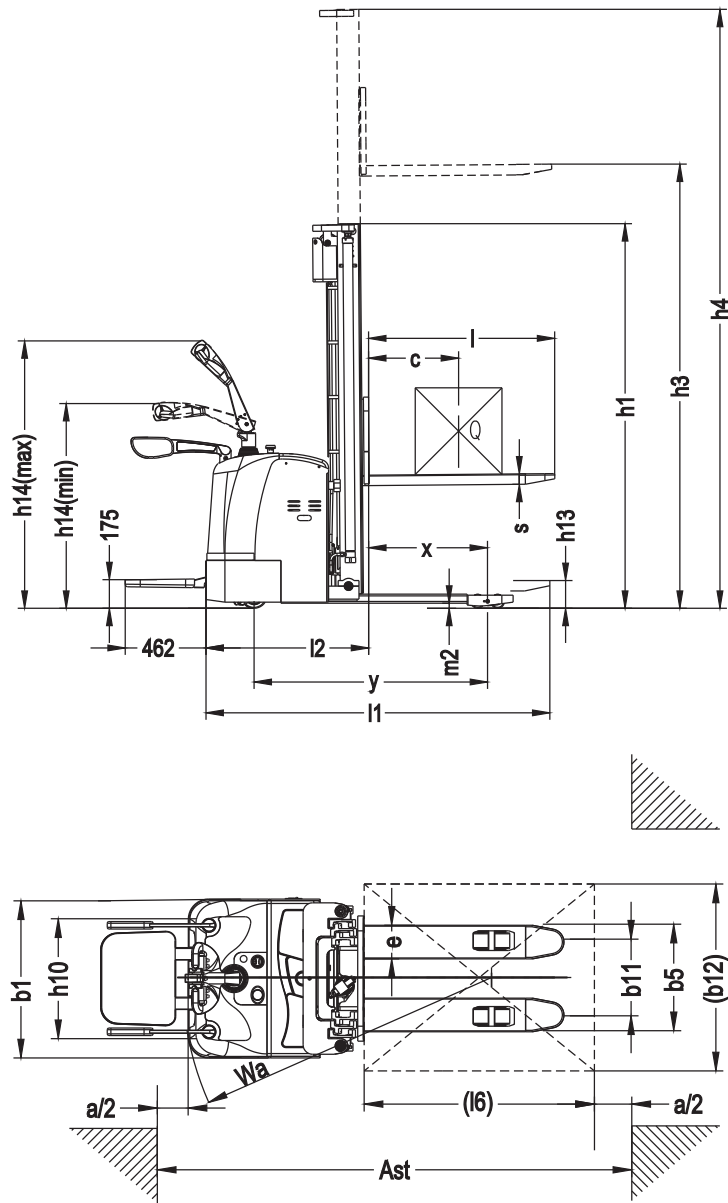

Option

- Traveling speed 6 km/h
- Integrated Charger (24V / 40A)
- Coldstore specification -18°C
- Keyless ignition (keypad)
- Battery trolley
- Initial lift
- Fork length (mm) 800; 900; 1000; 1200
- Lifting height 2500 mm, Duplex mast without free lift
- Lifting height 3000 mm, Duplex mast without free lift
- Lifting height 3300 mm, Duplex mast without free lift
- Lifting height 3500 mm, Duplex mast without free lift
- Lifting height 2500 mm, Duplex mast with free lift
- Lifting height 3500 mm, Duplex mast with free lift
- Lifting height 4500mm, Triplex mast with free lift
- Lifting height 5000mm, Triplex mast with free lift
- Lifting height 5600mm, Triplex mast with free lift

Specification (according to VDI 2198)

Characteristics				
1.1	manufacturer (abbreviation)			Hyundai
1.2	Model			15ESR
1.3	Drive type			electric
1.4	Operator type			pedestrian / standing
1.5	Load capacity/rated load	Q	kg	1500
1.6	Load center distance	c	mm	600
1.8	Load distance	x	mm	672
1.9	Wheelbase	y	mm	1378
Weight				
2.1	Service weight(with battery)		kg	1280
2.2	Axle load, front/rear, loaded		kg	1470/1310
2.3	Axle load, front/rear, unloaded		kg	900/380
Wheels/Chassis				
3.1	Tyres: solid rubber, superelastic, pneumatic, polyurethane			polyurethane
3.2	Tyre size, front			φ 250 × 70
3.3	Tyre size, rear			φ 80 × 84
3.4	Additional wheels(dimensions)			φ 150 × 60
3.5	Wheels number, front/rear (x = driven wheels)			1x +2/4
3.6	Tread, front	b10	mm	580
3.7	Tread, rear	b11	mm	404 / 530
Dimension				
4.2	Height of mast, lowered	h1	mm	1735 / 1985 / 2135 / 2235 / 2050 / 2210 / 2410
4.4	Lift height	h5	mm	1300 / 1550 / 1700 / 1800 / 1570 / 1740 / 1940
4.5	Max. height of mast, extended	h3	mm	2500 / 3000 / 3300 / 3500 / 4500 / 5000 / 5600
4.7	Lifting height for leg	h4	mm	2955 / 3455 / 3755 / 3955 / 5070 / 5550 / 6150
4.9	Min. /Max. height of operation handle, in driving position	h14	mm	1150 / 1450
4.15	Height, lowered	h13	mm	90
4.19	Overall length	l1	mm	2020 / 2100
4.20	Length to fork face	l2	mm	950
4.21	Overall width of truck body	b1	mm	850
4.22	Fork dimension	s/e/l	mm	60 / 180 / 1070 (1150)
4.25	Overall width of fork	b5	mm	570 / 695
4.32	Wheelbase ground distance	m2	mm	31
4.33	Aisle width, with pallet 1000 x 1200 crosswise	Ast	mm	2535
4.34	Aisle width, with pallet 800 x 1200 lengthwise	Ast	mm	2515
4.35	Turning radius	Wa	mm	1655
Performance Data				
5.1	traveling speed, loaded/unloaded		km/h	8.5 / 8.7
5.2	Lifting speed, loaded/unloaded		m/s	0-0.12 / 0-0.19
5.3	Lowering speed, loaded/unloaded		m/s	0-0.35 / 0-0.12
5.8	Max. gradeability, loaded/unloaded			8 / 15
5.10	traveling brake			electromagnetic brake
Motor				
6.1	Driving motor power		kW	1.5 (AC)
6.2	Lifting motor power		kW	3.2
6.4	Battery voltage/rated capacity		V/Ah	24 / 300
6.5	Battery weight		kg	300

Manual Hand Pallet Truck

25HP/25HPW

Standard Configurations

25HP

- Lifting Capacity : 2500 kg
- Polyurethane drive steering wheel
- Double Polyurethane load wheels
- Overall Fork Width x Length : 550 mm x 1150 mm
- 210° steering arc

25HPW

- Lifting Capacity : 2500 kg
- Double Polyurethane load wheels
- Overall Fork Width x Length : 550 mm x 1150 mm
- 210° steering arc
- Weighing Scale

Option

- Nylon drive wheel and double nylon load wheels
- Rubber drive wheel and double Polyurethane load wheels
- Polyurethane drive wheel and single Polyurethane load wheels
- Nylon drive wheel and single nylon load wheels
- Fully rubber wrapped handgrip
- Quick lift (5 strokes to reach max.height)
- Fork length (mm): 800; 900; 1000; 1100; 1220
- Overall fork Width x Length: 685 x 1150 mm
- Foot pedal release
- Foot pedal release extra long



■ Photo may include optional equipment.

Dimension & Specification (according to VDI 2198)

25HPW

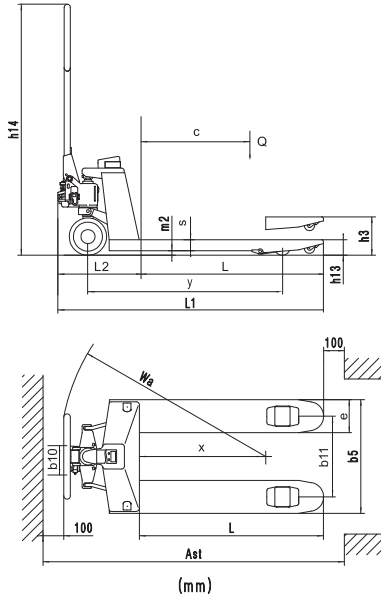

25HP

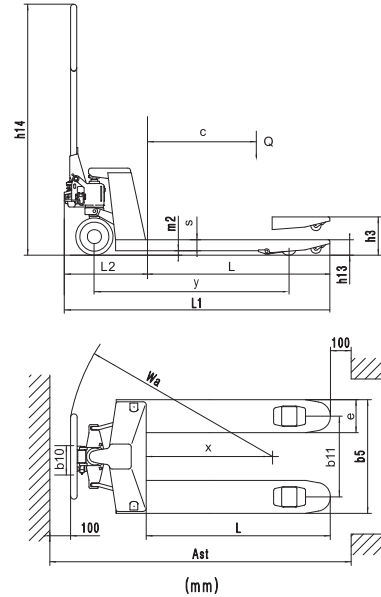

Characteristics					
1.1	Manufacturer(abbreviation)			Hyundai	Hyundai
1.2	Model			25HPW	25HP
1.3	Drive type			manual	manual
1.4	Operator type			hand	hand
1.5	Load capacity/rated load		kg	2500	2500
1.6	Load center distance	c	mm	40	32 / 22
1.8	Load distance	x	mm	600	600
1.9	Wheelbase	y	mm	1124 / 1194	1153 / 1223
Weight					
2.1	Service weight		kg	60-80	58-70
Wheels/Chassis					
3.1	Tyres: solid rubber, superelastic, pneumatic, polyurethane			polyurethane	polyurethane
3.2	Tyre size, front(Steering wheel)		mm	Φ 200	Φ 200
3.3	Tyre size, rear(Fork wheel single)		mm	Φ 80 x 93	Φ 80 x 93
	Tyre size, rear(Fork wheel tandem)		mm	Φ 80 x 70	Φ 80 x 70
3.5	Wheels number, front/rear (x = driven wheels)			2x+2/4	2x+2/4
3.6	Tread, front	b10	mm	120	111
3.7	Tread, rear	b11	mm	360 / 390 / 525	360 / 390 / 525
Dimension					
4.4	Max. Lift height	h3	mm	200	195
4.9	Min. /Max. height of operation handle, in driving position	h14	mm	1224	1224
4.15	Height, lowered	h13	mm	85 / 75	85 / 75
4.19	Overall length	l1	mm	1383 / 1483 / 1533 / 1603	1543 / 1613
4.20	Length to fork face	l2	mm	384	393.5
4.22	Fork dimension	s/e/l	mm	45 / 160 / (1150 / 1220)	53 / 160 / (1150 / 1220)
4.25	Overall width of fork	b5	mm	520 / 550 / 685	520 / 550 / 685
4.32	Wheelbase ground distance	m2	mm	32	32
4.33	Aisle width, with pallet 1000x1200 crosswise	Ast	mm	1683 / 1733 / 1803	1743 / 1813
4.34	Aisle width, with pallet 800x1200 lengthwise	Ast	mm	1783 / 1783 / 1803	1783 / 1813
4.35	Turning radius	Wa	mm	1216 / 1266 / 1336	1276 / 1346

- * Standard and optional equipment may vary per country. Contact your Hyundai dealer for more information.
- * The photos may include attachments and optional equipment that are not available in your area.
- * Materials and specifications are subject to change without advance notice.
- * All imperial measurements rounded off to the nearest pound or inch.



Conforms to EN ISO3691-1:2012
EN1175-1:1998/A1:2010
EN16307-1:2013

PLEASE CONTACT



HHF037A, Industrial estate BBG3000, HAL-FAR
Malta
info@rcvmalta.com
+(356) 2148 5681

