

# Hand Stacker PZ SERIES

## MT / GT series

- ▲ Unique technology of quick lift system.
- ▲ Compact design and strong, accurate steel construction.
- ▲ Top quality 1 piece "C" section forks for greatest strength.
- ▲ Top of stroke bypass valve built in.
- ▲ **Conforms to EN1757-1:2001.**

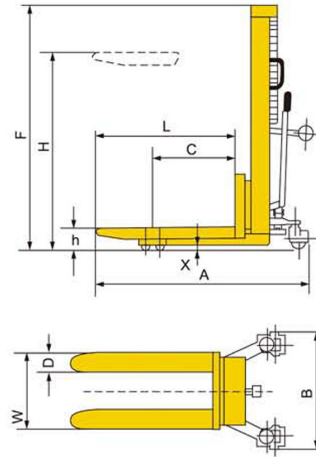

i-Lift No.	1520601	1520602	1520701	1520702
Model	MT1015	MT1029	GT1015	GT1029
Type	Standard		Straddle Leg	
Capacity (kg)	1000		1000	
Load Centre C (mm)	550	550	550	550
Max. Fork Height H (mm)	1500	2850	1500	2850
Min. Fork Height h (mm)	90		65	
Fork Length L (mm)	1150		1150	
Single Fork Width D (mm)	160		160	
Overall Fork Width W (mm)	540		540	
Leg Width (inside) W1 (mm)	—		1270	
Load Roller (mm)	Φ78×80		Φ78×80	
Steering Wheel (mm)	Φ150×38		Φ150×38	
Overall Length A (mm)	1595		1690	
Overall Width B (mm)	760		1395	
Overall Height F (mm)	1970	2000	1960	2000
Net Weight (kg)	230	370	250	390

Note: Materials and specification are subject to change without notice.

"RCV HANDLING MACHINERY" :: HHF 037A, Industrial Estate, BBG 3000, HAL-FAR, Malta

Tel: +356 2148 5681 :: Fax: +356 2144 1747 :: Mob: +356 9905 4096

Vat Nr. MT1467-3111

email: [info@rcvmalta.com](mailto:info@rcvmalta.com) :: Web: [rcvmalta.com](http://rcvmalta.com)