

# Lui 460



The latest in technology promotes safety and dependability through its design.

Safety is our number one priority. The LUI 460 eliminates the need for scaffold, scissor lifts and push around units. No ladders, no outriggers, no carrying parts, no hassles! One man (though rated for two) can easily do the job safely, quickly and efficiently.

Ready to take on the most demanding rental fleet challenges, the LUI 460 is ruggedly built and durable, while maintaining a high degree of mobility.

Its unique platform, mast and cylinder design allows an unheard of unrestricted platform capacity of 280 Kg (617 Lbs), with or without the extension of both decks.

*Work just became fun again.....*



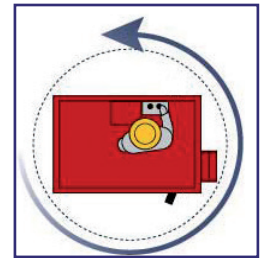
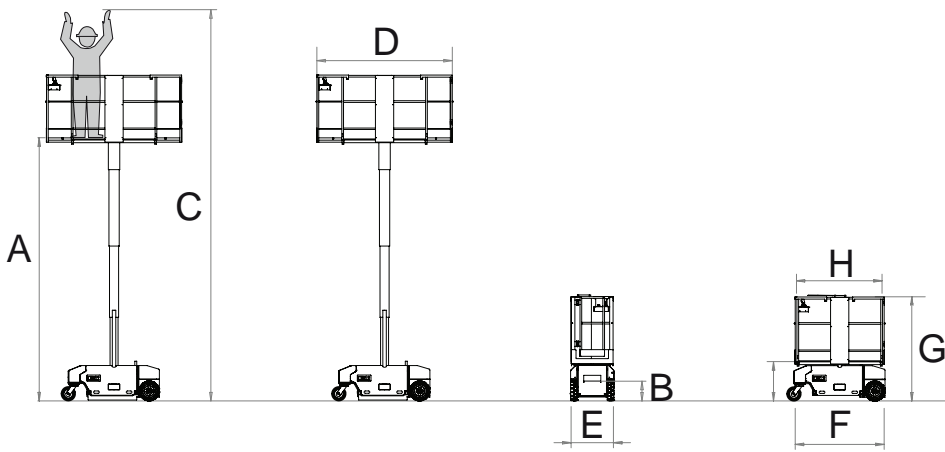

**ZERO Inside Turning Radius  
and 1700mm (67")  
Outside Turning Radius**

<b>MODELS</b>	<b>LUI 460</b>	
	Metric	US
<b>MEASUREMENTS</b>		
Platform Height	4620 mm	A 15 ft 2 in
Entry Step	340 mm	B 13.6 in
Working Height	6620 mm	C 21 ft 8 in
Platform Width	680 mm	2 ft 3 in
Platform Length W/decks ext	2376 mm	D 7 ft 9.5 in
Width	760 mm	E 2 ft 5 in
Length Stowed	1560 mm	H 5 ft
Height Stowed	1855 mm	G 6 ft 1 in
Base Length	1659	F 5 ft 4 in
Platform Capacity w/ decks ext	280 kg	616 lbs
Ground Clearance	100 mm	4 in
Rated Number of Occupants	2	2
<b>PERFORMANCE</b>		
Drive Speed Stowed	3 km/h	1.9 mph
Drive Speed Elevated	0,6 km/h	0.35 mph
Inside Turning Radius	Zero	Zero
Outside Turning Radius	1700 mm	67 in
Gradeability	35%	35%
Raise/Lower Speed	25 / 16 sec	25 / 16 sec
Controls	One Hand Proportional Controller	
Tires	Solid Rubber, Non Marking	
<b>POWER</b>		
Power Source	24 V c.c.	24 V c.c.
Batteries	4 -6V; 245 AH@20h	4 -6V; 245 AH@20h
Unit Weight	1250 kg	2755 lbs
<b>STANDARD COMPLIANT</b>	Ansi A92.6, CE Compliant, AS1418.10 (int)	

Able to drive through standard doors without having to leave the platform.

With 35% gradeability, it can easily climb a ramp or over beavertails into a truck, van, or pickup. It also features a tow hook for roll-back trucks, all accomplished while using a removable platform control box.

Wheel-locking device allows driving forward/backward in a straight line. Dual platform decks extend without sacrificing any platform capacity.

Powered by 4 TROJAN 6 volt batteries that produce a duty cycle of over 460 lift cycles or the ability to drive in excess of 9 Km (5.6 miles), then easily recharged in hours using its on-board charger. These High Amp batteries provide enough duty cycle for even the hardest of work days and more.

Large LCD readout in the ground module provides system diagnostics and status.

With its rugged ultra compact and versatile design, our one hand proportional control creates precise and safe operations and withstands all the demanding rental applications.

Platform entry is achieved using a step 340 mm (13.6") off the ground and then through a single style swing gate.

Built in tilt sensor, flashing light and audible alarm are all standard features.