



STAGE



15/18/20L-7M

LPG forklift with 500 mm load centre



**ECONOMICAL
ENGINE**



**HEAVY-DUTY
POWER TRAIN**



**VERY COMPACT
MACHINE**



**FULL CONTROL
CLUSTER**



**BEST STANDARD
WARRANTY**

STAGE V AND BEYOND

Hyundai's new L-7M Series is the purest form of its generation of LPG forklifts complying with the European Stage V emission levels. But it goes much further than that!

Dedicated to their mission, 'Moving you Further', our engineers aimed for a **ground-breaking level of customer satisfaction** with **maximum performance and productivity**, higher **operator comfort**, better **safety** and **improved uptime management**.

Combining a robust exterior design with very compact dimensions, our new L-7M forklifts open up a world of new possibilities to tackle all the challenges you face in your logistics business.



Productivity & Efficiency

POWERFUL AND FUEL-EFFICIENT TO REDUCE YOUR COSTS

The Hyundai legacy of reliable technology continues with an optimised engine. This fully electronically controlled engine in combination with a high-end LPG system with a catalyst, has demonstrated its efficiency over the last ten years. Compliance with the European Stage V environmental regulation was achieved by adding one sensor. This proven technology stands for high durability and the lowest possible fuel consumption.

Unparalleled fuel efficiency **NEW**



The L-7M Series is equipped with a powerful 2.4L HMC L4KB LPG engine that produces 37.3 KW while complying with the Europe's Stage V emissions standards. It also achieves **impressive cost savings** by delivering excellent performance with low fuel consumption rates.



- Featuring the optimal displacement for a forklift, the HMC L4KB engine comprises a timing chain, a high-end electronically controlled LPG system with a catalytic converter and two oxygen sensors.
- The adaptive LPG system continuously seeks the most fuel-efficient way of running, in order to keep the total cost of ownership (TCO) as low as possible.
- A speed reduction switch mounted on the dashboard activates a driving speed limiter. The speed limit is programmable.

Forklift standard warranty*

2 years

or 2,000 hours, whichever comes first.

Excellent driving performance

The powerful, high-output engine provides greater acceleration, better gradeability and faster travel speed on any tough terrain or slope.

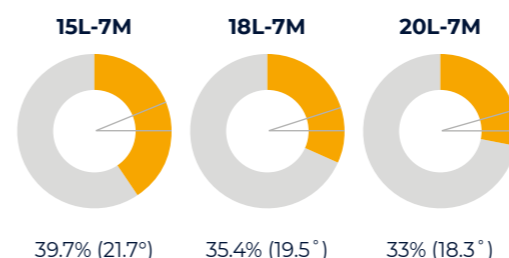

Maximum gradeability (loaded)

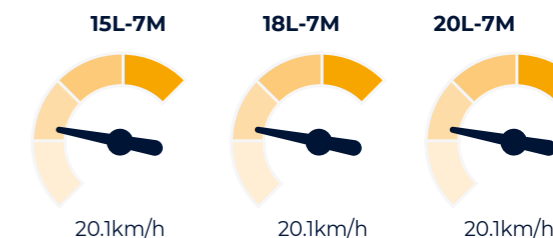

Maximum travel speed (unloaded)

Low fuel consumption

We tested the fuel consumption of the 18L-7M compared to three different competitor machines. All machines were tested with a **1 lb gas bottle and under the same conditions**. Thanks to the high-end LPG system, the Hyundai forklift **runs longer with the same amount of gas**.

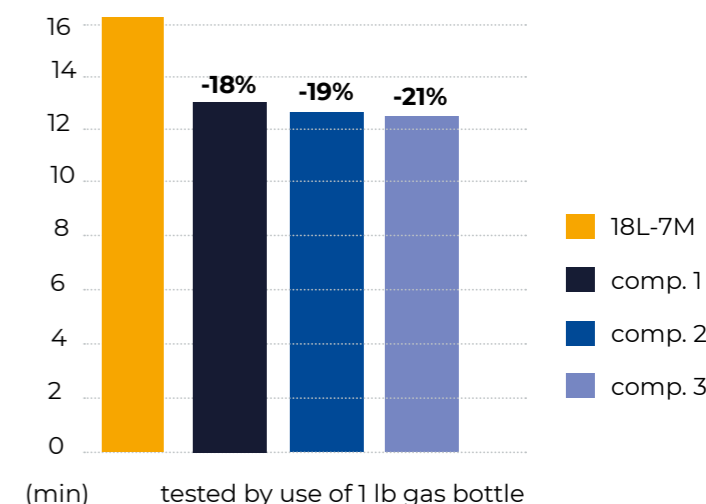

Speed reduction mode

A **speed limit** can be programmed in advance and activated using a switch on the dashboard.

*Conditions are subject to change. Please contact your dealer for the latest information and to find the optimal solution for your needs.

Productivity & Efficiency

A LEGACY OF EXCELLENCE: HIGH-DURABILITY POWER TRAIN

The transmission and the drive axle with wet disc brakes have proven their durability in the toughest applications. They are mounted on rubber dampers which significantly reduce noise and vibration, providing a smoother driving experience. The power train comes with an exceptional warranty programme.



The drive axle is equipped with a planetary reducing gear offering resistance to torque changes. Wet disc brakes ensure optimal brake performance with every application. Thanks to longer service intervals, the wet disc brake system also reduces maintenance costs and downtime.



The rear axle features a heavy-duty design with tapered bearings for increased durability.

Operator Comfort

OUTSTANDING ERGONOMICS FOR PRODUCTIVITY AND OPERATING PLEASURE

The cabin is designed to provide every operator with a comfortable working environment that boosts productivity and reduces fatigue, even in tough working conditions. The most important controls are positioned within easy reach.



* Photo may include optional equipment

“I’m really impressed by how smooth and quiet it is. It’s a completely different driving experience!”

Better visibility and cabin comfort

The mast, carriage, and head guard are designed to provide the operator with maximum visibility for improved efficiency and peace of mind while working.



Low step-up height



A low step-up height and a hand grip on the head guard enable safe, convenient access to the machine.

Multi-functional levers



The multi-functional levers are conveniently positioned next to the steering wheel.

Adjustable steering column

The steering column can be adjusted using a simple hand grip, making it easy to find the most comfortable position. The parking brake and hazard switch are perfectly positioned within the operator’s reach.



Foot space

All pedals are ergonomically arranged to ensure maximum comfort for the operator.



Operator Comfort

TECHNOLOGY AT YOUR FINGERTIPS FOR FULL CONTROL

The enhanced cluster makes it easier to manage and control all key functions.

Instrument cluster

1. Parking brake
2. Brake fluid level warning
3. Engine check lamp
4. Engine coolant temperature
5. Indicators
6. Engine oil pressure warning
7. Transmission temperature warning
8. Battery control
9. Air filter warning
10. Head lamp high beam
11. Hour meter
12. OPSS control
13. Seat belt control

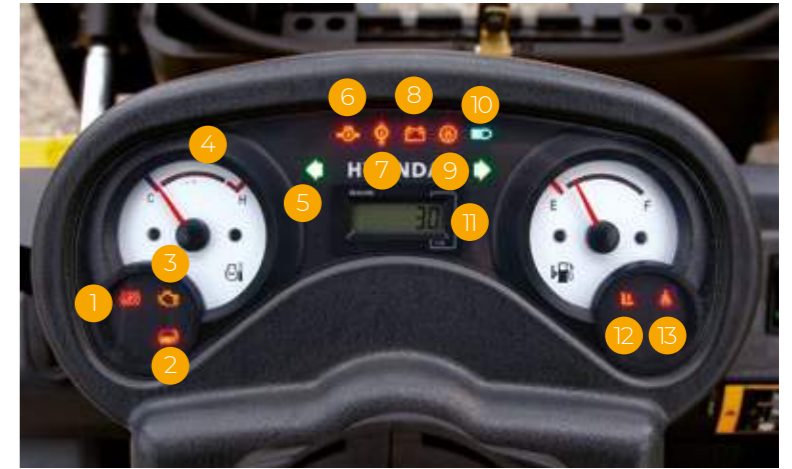

The simple clear cluster layout provides the operator with essential information. The waterproof design protects it in wet conditions.

Hydraulic levers for perfect control



The hydraulic control levers are ergonomically positioned to ensure optimal control.

"The cabin is incredibly comfortable – everything is easy to reach, I have full control and I don't feel tired at all at the end of the day. The fingertip control is optional but, in my opinion, every customer should take it – it's easy, precise and fully programmable."

Cup holder and utility box



A handy cupholder, paper clip and utility box are placed next to the seat, within easy reach.

Parking brake lever



The ratchet-type lever allows application of the brake with a minimum of effort and secures the position of the machine under any circumstances.

Safety

CREATING A SAFER WORKING ENVIRONMENT

Small details can make a huge difference when it comes to safety and security. By helping to ensure an accident-free workplace, the new L-7M Series forklifts help you to achieve the peace of mind and productivity you need to safeguard your business.



Down control function

The lowering speed is controlled at all times and even slows down automatically in the event of a hydraulic hose failure to prioritise safety.

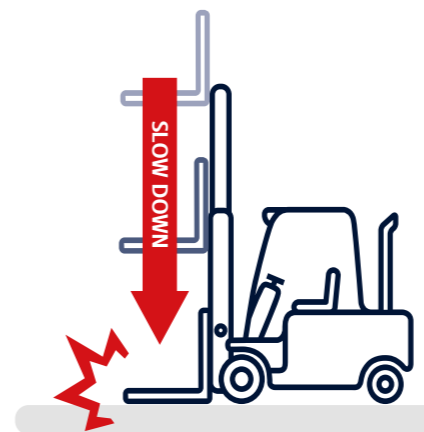

OPSS (Operator Presence Sensing System)

The OPSS System restricts driving, lifting and tilting, and kicks in automatically when the operator leaves the seat to prevent accidents. It operates in conjunction with the auto parking brake to contribute to a safer workplace.



- DRIVE LOCK
- LIFT LOCK
- TILT LOCK

Halogen lights

Halogen lights offer optimal visibility in any circumstances.



Overhead guard

The Press Type overhead guard has passed the strictest safety tests and can be provided with a rain cover.



Heavy-duty frame

The frame is a one-piece unit designed for maximum safety and durability.



Grammar seat

The low-vibration Grammar seat with standard seat belt offers maximum comfort and safety for the operator.



* Photo may include optional equipment

Serviceability

BUILT FOR QUICK, EASY SERVICING

The peace of mind that comes with fast, low-effort servicing is also part of the Hyundai L-7M Series philosophy. These forklifts are designed to make maintenance as convenient as possible. All components and materials have been optimised to ensure a long, trouble-free service life.



Easy maintenance

The wide-opening engine hood and tool-less removable panels **reduce equipment downtime** by providing easy access to parts requiring regular maintenance.



Easy access

Access to all service-related parts is quick and easy thanks to removable body panels. This **reduces downtime and service costs**.



Radiator access

Easy access to the radiator makes it easy to check and clean the cooling system. This helps to prevent overheating, a common cause of engine failure problems.



Fuse and relay boxes

The engine fuses and relays are centralised in two boxes with enhanced protection. The engine fuses are placed next to the battery. The machine fuse box is integrated into the dashboard for quick access.



Parts & Warranties

HYUNDAI GENUINE PARTS AND WARRANTIES: THE BEST WAY TO PROTECT YOUR INVESTMENT

Hyundai Genuine parts, accessories and warranty programmes are specially designed to keep your investment covered. They increase uptime and maintain the performance, comfort, and convenience that are built into your equipment.



Leader in standard warranties for Stage V forklifts!

Hyundai warranties are designed to give you the cover you need to build your business with confidence and peace of mind.

Best standard warranties in the industry

For extra reassurance, and to ensure maximum customer confidence, we are supplying all new stage V models with best industry standard warranties.

The forklift **standard warranty covers you for two years or 2,000 hours, whichever comes first.***



Optional and extended warranty periods

In addition to this standard coverage, optional and extended warranty periods are available, allowing you to benefit from full warranty coverage for longer, and even over the full lifetime of your forklift.*

Forklift standard warranty*

2 years

or 2,000 hours, whichever comes first.

Hyundai Genuine parts

Hyundai Genuine parts have the same design as those installed when your machine left the factory. They are subjected to rigorous quality inspections and tests to make sure they meet Hyundai's strict requirements for quality and durability. As well as minimising downtime, this helps to

ensure peak performance in every task. In the 13,000 m² warehouse, Hyundai covers over 96% of all Genuine Parts. With one of Europe's most advanced automated warehousing systems, we are able to maintain availability and efficient delivery of all our Genuine Parts.

A network you can rely on

HCEE prioritises quick, reliable intervention to keep your equipment running reliably. Thanks to the **extended dealer network across Europe, we will always be close by to ensure a timely and efficient solution.** Moreover, we guarantee a 24-hour delivery service across our European dealer network.

* Conditions may be subject to change. Please contact your dealer to have the latest information and find the optimal solution for your needs.

Specifications

15/18/20L-7M

STANDARD AND OPTIONS

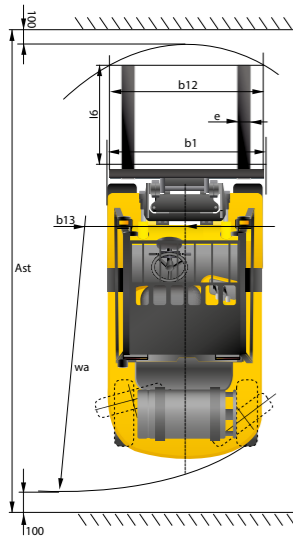
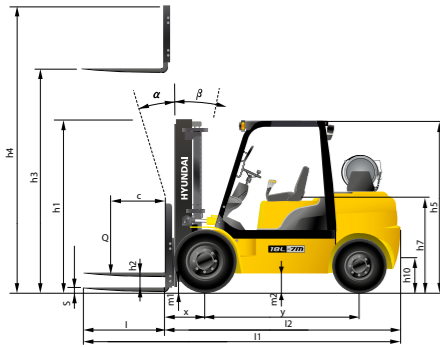

Main characteristics				Hyundai	Hyundai	Hyundai
1.1	Manufacturer			Hyundai	Hyundai	Hyundai
1.2	Manufacturer's model designation			15L-7M	18L-7M	20L-7M
1.3	Drive			LPG	LPG	LPG
1.4	Type of operation			seated	seated	seated
1.5	Load capacity	C	kg	1,500	1,750	2,000
1.6	Load center distance	x	mm	500	500	500
1.8	Load distance (center of drive axle to fork)	y	mm	393	393	398
1.9	Wheelbase		mm	1,410	1,410	1,410
Weights						
2.1	Service weight		kg	2,691	2,861	3,046
2.2	Axle loading, loaded	front / rear	kg	3,640 / 550	4,006 / 605	4,380 / 660
2.3	Axle loading, unloaded	front / rear	kg	1,190 / 1,500	1,147 / 1,714	1,106 / 1,939
Tyres/Chassis						
3.1	Tyres			Pneumatic	Pneumatic	Pneumatic
3.2	Tyre size	front		7.00-12-12PR	6.5 x 10 x 12PR	6.5 x 10 x 12PR
3.3	Tyre size	rear		6.50-10-12PR	5.0 x 8 x 10PR	5.0 x 8 x 10PR
3.5	Number of wheels (x = driven wheels)	front / rear		2 x 2	2 x 2	2 x 2
3.6	Tread	front	mm	999	890	890
3.7	Tread	rear	mm	980	910	910
Dimensions						
4.1	Tilt of mast / fork carriage forward / backward	α / β	degree	6 / 10	6 / 10	6 / 10
4.2	Height, mast lowered	h1	mm	2,155	2,155	2,155
4.3	Free lift	h2	mm	145	145	150
4.4	Lift height	h3	mm	3,325	3,325	3,330
4.5	Height, mast extended	h4	mm	4,332	4,332	4,332
4.7	Height of overhead guard	h5	mm	2,110	2,110	2,110
4.8	Seat height / stand height rel. to SIP	h7	mm	1,128	1,050	1,129
4.12	Coupling height	h10	mm	271	271	270
4.19	Overall length	l1	mm	3,133	3,163	3,208
4.20	Length to face of forks	l2	mm	2,233	2,263	2,308
4.21	Overall width	b1	mm	1,070	1,070	1,070
4.22	Fork dimensions	l x e x s	mm	900 x 100 x 35	900 x 100 x 35	900 x 100 x 40
4.23	Fork carriage ISO 2328, Class / Type A, B			II / A	II / A	II / A
4.24	Fork carriage width	b3	mm	1,004	1,004	1,004
4.31	Ground clearance, below mast, loaded	m1	mm	120	120	120
4.32	Ground clearance, center of wheelbase		mm	143	142	140
4.34.1	Aisle width for pallets 1,000 X 1,200 crossways	Ast	mm	3,594	3,620	3,660
4.34.2	Aisle width for pallets 800 X 1,200 lengthways	Ast	mm	3,794	3,820	3,860
4.35	Turning radius	Wa	mm	2,000	2,026	2,063
4.36	Smallest pivot point distance		mm	589	589	589
Performance data						
5.1	Travel speed	unloaded	km/h	20,1	20,1	20,1
5.2	Lift speed	loaded / unloaded	mm/s	650 / 680	650 / 680	650 / 680
5.3	Lowering speed	loaded / unloaded	mm/s	500 / 450	500 / 450	500 / 450
5.6	Max. drawbar pull	loaded	N	17,028	17,131	17,269
5.8	Max. gradeability	loaded	%	39,7	35,4	33
5.10	Service brake			Hydraulic	Hydraulic	Hydraulic
Engine						
7.1	Engine manufacturer / type			HMC L4KB	HMC L4KB	HMC L4KB
7.2	Engine power acc. to ISO 1585		kW / rpm (hp / rpm)	37.3 / 2,450	37.3 / 2,450	37.3 / 2,450
7.3	Maximum torque		kgfm / rpm	19 / 1,800	19 / 1,800	19 / 1,800
7.4	No. of cylinders / displacement		EA / cc	4 / 2,359	4 / 2,359	4 / 2,359
7.5	Fuel consumption acc. to Vdi cycle		l / h	-	-	-
Additional data						
8.1	Type of drive control		AC	Power Shift	Power Shift	Power Shift
8.2	Operating pressure, system / attachments		bar	187 / 147	187 / 147	187 / 147
8.3	Oil volume for attachments		LPM	60	60	60
8.5	Trailer coupling, type DIN			PIN	PIN	PIN

	Part	Description	15L-7M	18L-7M	20L-7M
OPERATOR AREA	OHG	Overhead guard: 2,110 mm	●	●	●
	Cabin	Top rain cover	○	○	○
	Seat	Full suspension synthetic leather seat + orange belt, arm rest, seat switch Seat accessories - belt switch, heated seat	● ○	● ○	● ○
MAST & ATTACHMENT	Lever	Lever - mechanical	●	●	●
	Mast	2 Stage mast - standard (V)	●	●	●
		3 Stage mast - dual full free (TS)	○	○	○
	Fork	900 mm fork	●	●	●
		Fork options - 900 mm-1,500 mm	○	○	○
	Carriage	Carriage - narrow (1,004 mm/hook)	●	●	●
		Carriage options	-	-	-
	Tilt angle	6° / 10°	●	●	●
		6° / 6°	○	○	○
		6° / 5°	○	○	○
3° / 3°		○	○	○	
Attachment	Hook-on side-shift	○	○	○	
	Integrated side-shift	○	○	○	
HYDRAULICS	MCV & Hoses	3 Spool MCV + attached piping for V330 mast	●	●	●
		MCV options - 4 spool	○	○	○
		Attached piping for all MCVs & masts	○	○	○
TYRES	Tyres	Tyre - pneumatic	●	●	●
		Tyre options	-	-	-
		- Solid	○	○	○
		- Non-Marking	○	○	○
VISIBILITY	Lamp	Working lamp - front bulb	●	●	●
		Working lamp - rear bulb	●	●	●
		LED beacon lamp	○	○	○
Mirror	Mirror - panorama	●	●	●	
SAFETY	-	OPSS - travel & mast	●	●	●
		Master switch to cut-off electricity from battery	●	●	●
		Hazard switch	○	○	○
		Speed control unit	○	○	○
OTHERS	LPG Bracket	LPG tank fixed type	●	●	●
		LPG tank swing-out type	○	○	○
		LPG tank swing-down type	○	○	○
Painting	Special color	○	○	○	
Filter	Engine pre-filter	○	○	○	

● STD / ○ OPT

* The above specifications are based on V300 mast.
 * In accordance with guideline 2198, this specification sheet provides details of the standard truck only.
 Non-standard tyres, different masts, optional equipment, etc. may result in different values.



* Standard and optional equipment may vary by country. Contact your Hyundai dealer for more information.

* The machine may vary according to International standards. European specifications may differ from Korean specifications mentioned in the brochures.

* The photos may include attachments and optional equipment that are not available in your area.

*Materials and specifications are subject to change without advance notice.

* All imperial measurements are rounded off to the nearest pound or inch.

Hyundai Material Handling Europe
Hyundailaan 4, 3980 Tessenderlo, Belgium
Tel: (+32) 14-56-2200 Fax: (+32) 14-59-3405

Contact your Hyundai dealer.
hyundai-mh.eu



Address



Handling Machinery LTD

HHF037A, Industrial estate
BBG3000 HAL-FAR
Malta

+356 2148 56 81

info@rcvmalta.com

 **HYUNDAI**
MATERIAL HANDLING